



# HOSHIZAKI



As we don't only use ice in the bar, we also use ice in the kitchen,



The drier the ice is, the longer it will stay frozen.

## CONTENTS

<b>ABOUT US</b>	<b>4</b>
<b>ICE MAKER</b>	
Why is Hoshizaki ice?	6
Ice types – Shapes & Size	8
<b>IM RANGE</b>	
Cube Ice – Choose Hoshizaki ice, choose perfection	10
IM line products	12
Special Shape Ice	16
<b>KM RANGE</b>	
Crescent Ice – Signature Design	18
KM line products	20
<b>FM RANGE</b>	
Flake & Nugget ice – Solution for fresh food	22
FM line products	24
<b>SRM RANGE</b>	
Dice ice line products - Budget price for local business	26
<b>ICE BIN &amp; ACCESSORIES</b>	<b>28</b>
<b>ICE DISPENSER</b>	<b>30</b>
<b>CHILLER &amp; FREEZER UPRIGHT</b>	
Standard line products	34
650 Depth line products	38
Long door line products	40
Pillarless line products	41
Glass door line products	42
Combo line products	44
Special refrigerator	46
<b>UNDERCOUNTER CHILLER &amp; FREEZER</b>	
Standard line products	50
750 Depth line products	52
600 Depth line products	54
Pillarless line products	56
Glass door line products	58
Multi drawers line products	60
Low drawers line products	62
GN salad display line products	64
<b>GN TRAY &amp; BAKERY TRAY</b>	<b>68</b>
<b>BLAST FREEZER</b>	<b>70</b>
<b>BACK BAR</b>	<b>72</b>
<b>SUSHI SHOWCASE</b>	<b>74</b>
<b>CAKE DISPLAY</b>	<b>76</b>
<b>NESTOR – GRILL NEST CLEANING</b>	<b>78</b>
<b>OUR WAREHOUSE</b>	<b>80</b>
<b>WARRANTY</b>	<b>82</b>
<b>BEER &amp; HIGBALL BUSINESS</b>	<b>84</b>





## STRONG FOUNDATION FOR LEADING FUTURE INNOVATION

## ABOUT US

*We continuously strive  
for further success*

The Hoshizaki Group is an all round manufacturer of kitchen equipment centered around Hoshizaki Corporation, which is responsible for manufacturing and the world headquarters for the group.

Hoshizaki has been introducing a variety of products including ice-makers to the market incorporating new technologies and creativities by boldly undertaking “challenges to the extreme” in accordance with our motto of “There is no corporate growth without our own original products” since the establishment of our company in 1947.

We have an extensive sales network with 15 sales companies and approximately 450 sales branches throughout Japan. Outside of Japan, we have established manufacturing and sales bases in the U.S., Europe and Asia. We are expanding our business around the world as a brand-name company with our Penguin company logo.

We own production bases in the U.S., Europe, China, India, Australia and Brazil where we manufacture products in order to deal quickly with the needs of local customers, and have also made strides in improving our marketing and services system in those areas.

Today our products serve a wide range of food requirements and are highly valued by many people in over 60 countries worldwide. We continuously strive for further success as a much-beloved global brand by respecting communication with our customers above all, and maximizing the collective strengths of the unity between manufacturing and sales.



Mr. Shigetoshi Sakamoto  
Tounder of Hoshizaki Cooperation

## HOSHIZAKI HISTORY

### 1947 - Established Hoshizaki

1981 - Established the sales branch in California, USA

1986 - Founded the first plant in Georgia, USA

1992 - Established the Hoshizaki Europe B.V. in Amsterdam, Netherland

1994 - Established the Hoshizaki Europe Ltd. in Shropshire, UK

1998 - Established the Beijing office

1999 - Established the Hoshizaki Singapore

### 2004 - Established the Hoshizaki Shanghai Ltd.

### 2006 - Founded plant in China

### 2008 - Official listed in Tokyo Stock Exchange

2010 - Established the Hoshizaki Hongkong Ltd., the Hoshizaki Taiwan Ltd.

### 2012 - Established the Hoshizaki Invest China Ltd.

2013 - Established the Hoshizaki Korea

2014 - Established Hoshizaki Indonesia Ltd.

2015 - Established Hoshizaki Thailand Ltd.

### 2016 - Established Hoshizaki Vietnam Ltd.

2017 - Established Hoshizaki Phillipine Ltd.





*Food Reserve & Display*



Hoshizaki's wide range of ice makers caters for a host of requirements and we have developed innovative solutions that are tailored to the demands of a wide range of locations and operations.

We call upon our vast technical know-how and end-user knowledge to design and develop ice makers for the production of variety of ice types, in addition to ice dispensers. You will see Hoshizaki ice making equipment and ice dispensing systems in front of house and back of house locations at the world's leading bar and restaurant brands, and you are just as likely to find them performing critical functions and deep fishing vessel.

Our ice makers are renowned for their outstanding performance and durability to withstand the toughest commercial pressures. The basic designs and major component parts are specified for a global market meaning that Hoshizaki machines will effortlessly and quickly achieve outstanding.

Market Segments		IM				KM			FM	DSM	DCM	IM Special Range				SRM		
		Cube XS	Cube S	Cube M	Cube L STANDARD	Cube XL	Big Cube	Cylinder	Crescent	Floko	Nugget	Shuttle	Cublet	Ball	Round	Star	Long Cube	Disc Ice
Hospitality	Bar/club	X	X	X	X	X	X	X	X		X		X	X	X	X	X	X
	Cocktail	X	X	X	X	X	X		X		X		X	X	X	X	X	X
	Hotel	X	X	X	X	X			X	X	X	X	X	X	X	X	X	
	Restaurants	X	X	X	X	X		X	X	X	X		X					
	Fastfood	X	X	X	X				X		X		X					
	Nightclub		X	X	X	X	X	X	X		X			X	X	X	X	X
Catering		X	X	X	X	X		X	X	X								
Education		X	X	X	X			X		X		X						
Healthcare	Laboratory								X	X	X	X						
	Hospital	X	X	X	X				X		X	X	X					
	Laser Therapy								X									
	Physiotherapy	X							X	X	X							
Food Processing	Packaged Food Display									X	X							
	Fresh Produce Display								X	X	X							
Marine			X	X	X		X	X	X	X	X	X	X	X	X	X	X	
Leisure		X	X	X	X				X		X							



*Ice for Beverage*



*Marine*



*Healthcare*

All Cubers are equipped with an electronic control system. This ensures an optimized ice making process, even under varying circumstances. Without additional manual assistance or adjustments required, our Cubers produce generous amounts of ice cubes, at a consistent high quality. As all impurities are eliminated from the water right at the beginning of the cubing process, the problem of malfunction due to calcification, mineral accumulation and incrustation is almost unknown to owners of Hoshizaki Cubers.

Furthermore, naturally occurring HC refrigerants only have a minimal global warming potential, compared to machines run with traditional HFC refrigerants. This has a positive impact on both the environment and your budget. As with all Hoshizaki Ice Makers, the Cubers are HACCP certified and known for continuously meeting the highest health, safety and hygiene standards.



TYPES OF ICE

CRESCENT ICE

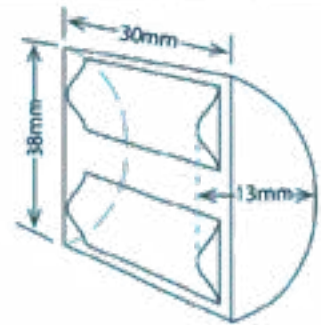

CUBES

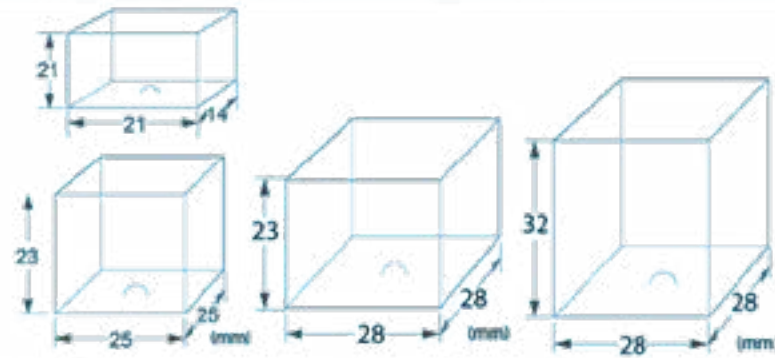

STAR ICE

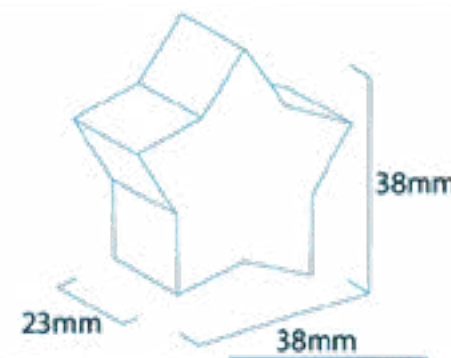

BALL ICE

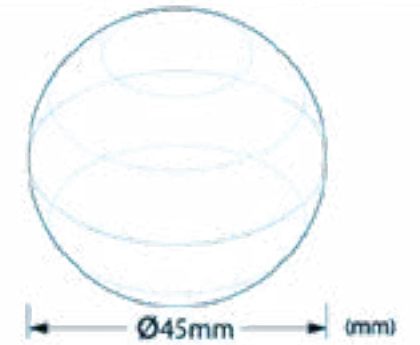

FLAKE ICE

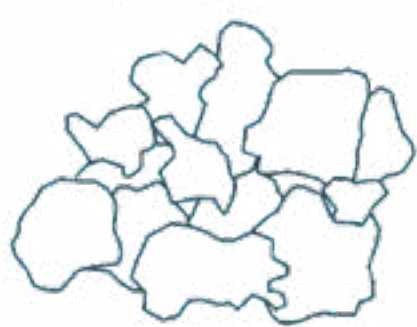

NUGGET ICE

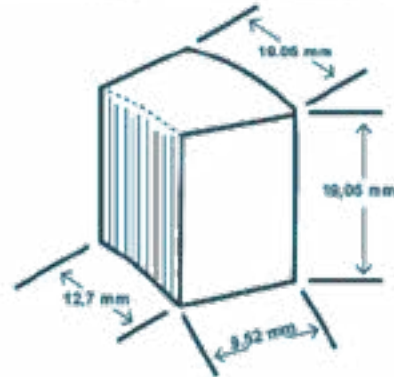

LARGE CUBE

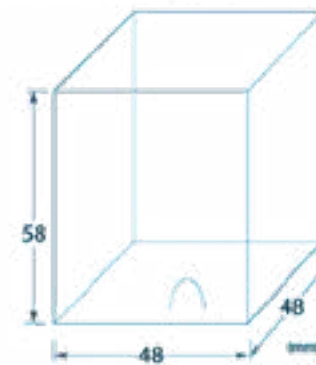

HEART ICE

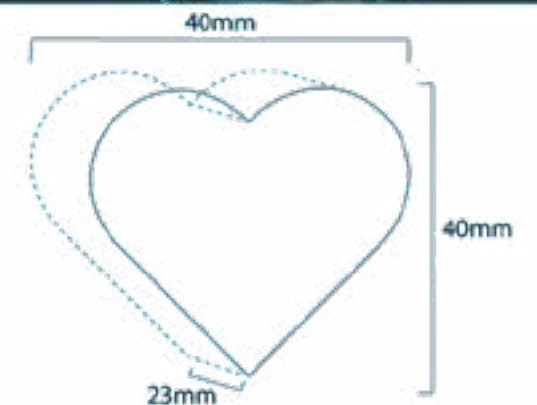



# CHOOSE HOSHIZAKI CUBE ICE CHOOSE THE PERFECTION



## CUBE ICE

### THE MARBLE EFFECT:

The appearance of the Hoshizaki cube is characterized by its clean edges and its transparency streaked by a marbling effect. This effect occurs, when the CELL WALLS block the freezing water's expansion from all sides, while reaching up to -30°C during the cubing process. As the temperatures go down, the water keeps expanding and marbles start to form as a sign of extreme density and compactness of every single cube.



Every bartender will tell you about the importance of the ice quality for their craft of creating layers of taste and texture in a cocktail glass. Premium spirits and ingredients simply ask to be paired with nothing less than ice cube perfection.

Hoshizaki cubes are extremely compact, dry, tasteless, consistently identical and slowly melting, allowing just the right amount of dilution – a combination of everything a bartender requires when it comes to aesthetics, taste and functionality of ice.

Cube ice is perfectly symmetrical and leaves a good impression with its hard crystal clear quality that melts very slowly, allowing customers to enjoy their favourite drinks longer. Hoshizaki's modular system cube ice makers are built to support the needs for large volumes in an establishment.

These modular systems placed on top of ice bins produces continuously with a model available for extended capacity. The IM series allows more flexibility of application with each range offering ice in variable capacity alongside a design for uncomplicated usage from start to finish.

### CUBE ICE SIZES

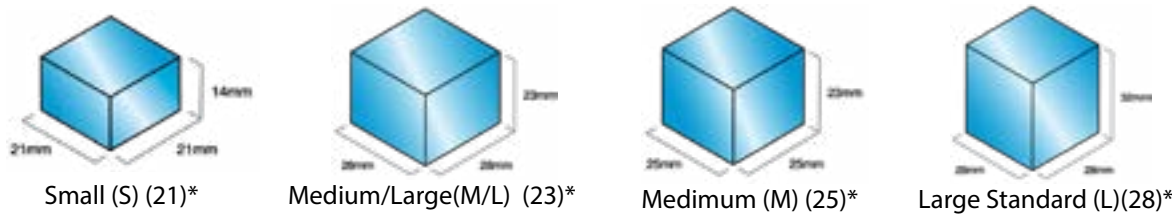

As we don't only use ice in the bar, we also use ice in the kitchen,